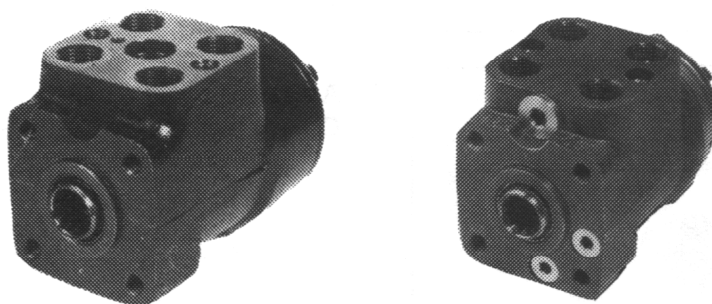

WINGET

The Danfoss logo is displayed in a white, cursive script font against a solid red rectangular background.

OSPB/OSPC HYDROSTATIC STEERING UNIT SERVICE MANUAL

WINGET LIMITED
PO BOX 41
EDGEFOLD INDUSTRIAL ESTATE
PLODDER LANE
BOLTON
LANCS
BL4 OLS

Tel:++ 44 (0) 1204 854650
Fax:++ 44 (0) 1204 854663
parts@winget.co.uk
service@winget.co.uk
www.winget.co.uk

INTRODUCTION

This Service Manual is applicable to the Danfoss OSPB & OSPC Hydrostatic Steering Valves installed on Winget equipment.

Winget Limited do not recommend that attempts are made to repair faulty Steering Valves however in recognition of the fact that this advice is not always practicable Winget Limited have released this manual subject to the following disclaimer.

The contents of this manual although correct at the time of publication may have been subject to alteration by the manufacturers without notice and Winget Limited can accept no responsibility for any errors or omissions contained within the following pages. Nor can we accept any liability whatsoever arising from the use of this manual howsoever caused.

Winget Limited operate a policy of continuous product development. Therefore, some illustrations or text within this publication may differ from your machine.

WINGET LIMITED
PO BOX 41
EDGEFOLD INDUSTRIAL ESTATE
PLODDER LANE
BOLTON
LANCS
BL4 OLS
TEL ++ 44 (0) 1204 854650
FAX ++ 44 (0) 1204 854663
E mail service@winget.co.uk
parts@winget.co.uk
www.winget.co.uk



Hydrostatic Steering Unit OSPB/OSPC

HN.21.AD.02 replaces HN.21.AC.02



		Page
Table of contents	Cost-free repairs	2
	Tools	2
	Dismantling	8
	Reassembling	14
	Max. tightening torque and hydraulic connections	28
	Service shops.....	29
	Exploded view: OSPB / OSPC / OSPC LS.....	29-30



Cost-free repairs

We would point out that cost-free repairs as mentioned in Danfoss General Conditions of Sale, are carried out only at Danfoss Nordborg or at service shops authorized by Danfoss (page 29).

TOOLS

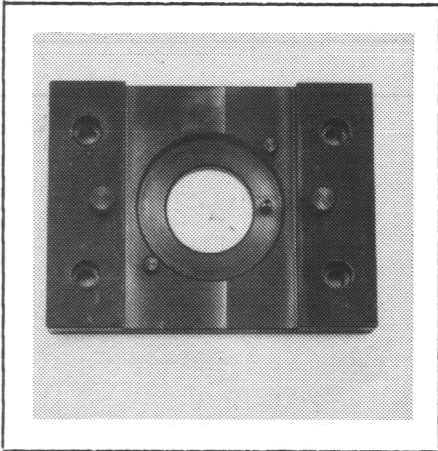

A Holding tool. Code no.: SJ 150-9000-2.

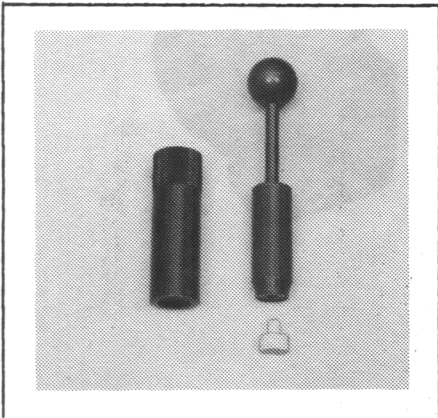

B Assembly tool for o-ring and kin-ring.
Code no. SJ 150-9000-11.

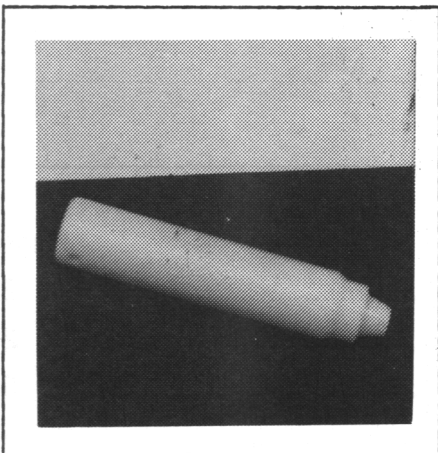

C Assembly tool for lip seal.
Code no. SJ 150-9000-17.

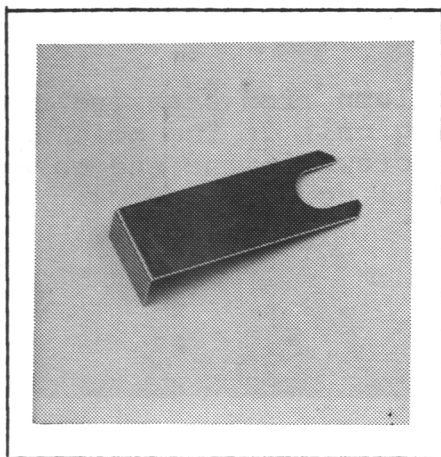

D Assembly tool for cardan shaft.
Code no. SJ 150-9000-3.

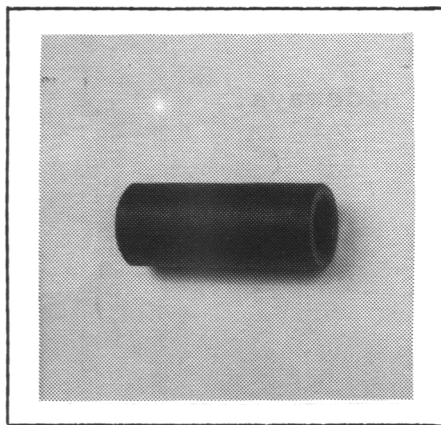

E Assembly tool for dust seal.
Code no. SJ 150-9000-22.

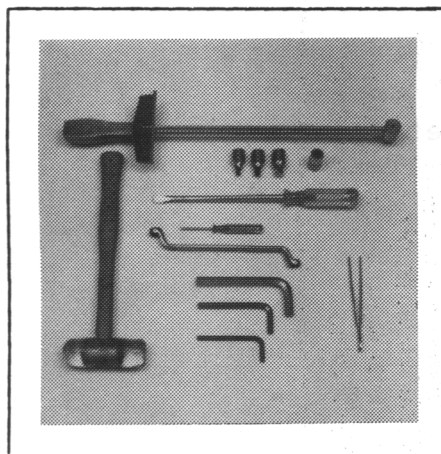

F Torque wrench 0-7 daNm.
13 mm socket spanner.
6, 8 and 12 mm hexagon sockets.
12 mm screwdriver.
2 mm screwdriver.
13 mm ring spanner.
6, 8 and 12 mm hexagon socket spanners.
Plastic hammer.
Tweezers.

The tools named under point F are not available from Danfoss.



DISMANTLING

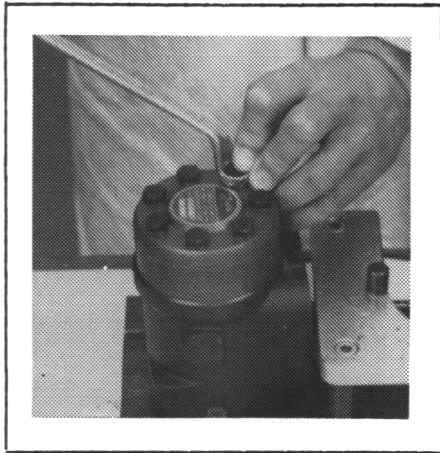

- 1 Dismantle steering column from steering unit and place the steering unit in the holding tool. Screw out the screws in the end cover (6-off plus one special screw).

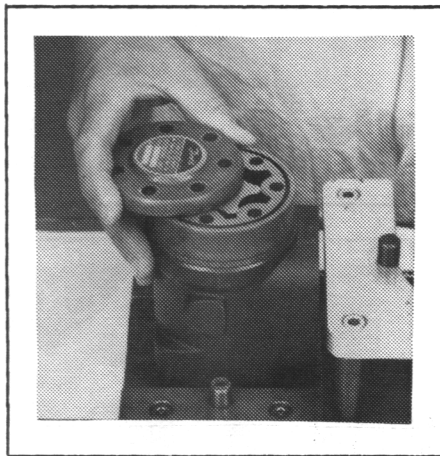

- 2 Remove the end cover, sideways.



- 3 Lift the gearwheel set (with spacer if fitted) off the unit. Take out the two o-rings.

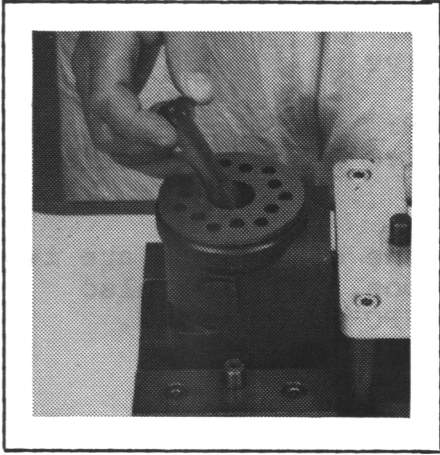

4 Remove cardan shaft.

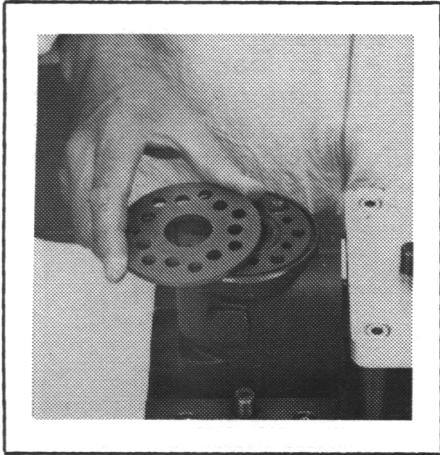

5 Remove distributor plate.

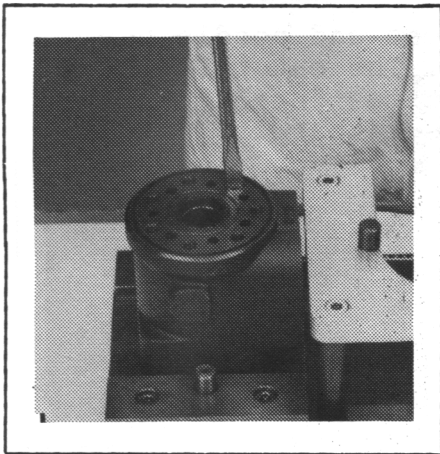

6 Screw out the threaded bush over the check valve.

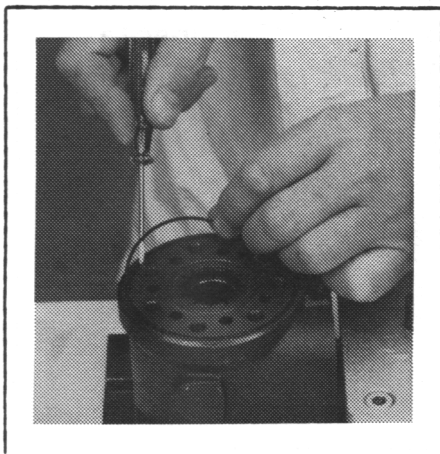

7 Remove o-ring.

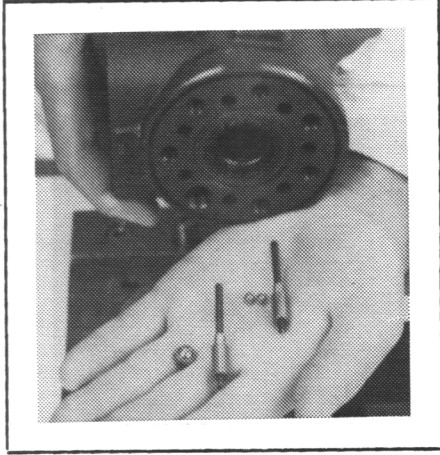

8 OSPB; OSPB LS; OSPBX LS:
Shake out the check valve ball (\varnothing 8 mm).

OSPC; OSPC LS; OSPC LSR:
Shake out the check valve ball and suction valve pins and balls.

Note: On some pins in the OSPC there are two springs (see page 30, pos. 28). See also spare parts list for OSPC HN.21.CA.52.

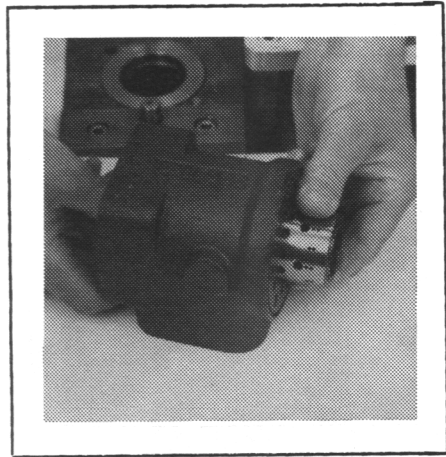

9 Take care to keep the cross pin in the sleeve and spool horizontal. The pin can be seen through the open end of the spool. Press the spool inwards and the sleeve, ring, bearing races and needle bearing will be pushed out of the housing together.

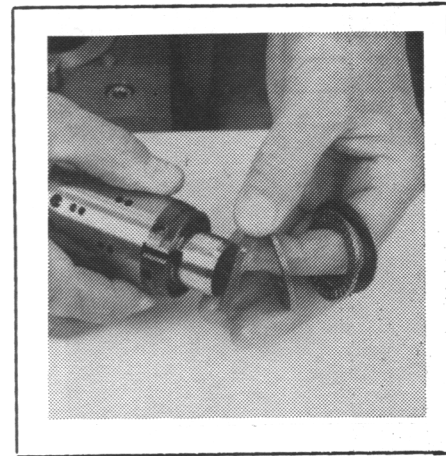

10 Take ring, bearing races and needle bearing from sleeve and spool. The outer (thin) bearing race can sometimes "stick" in the housing, therefore check that it has come out.

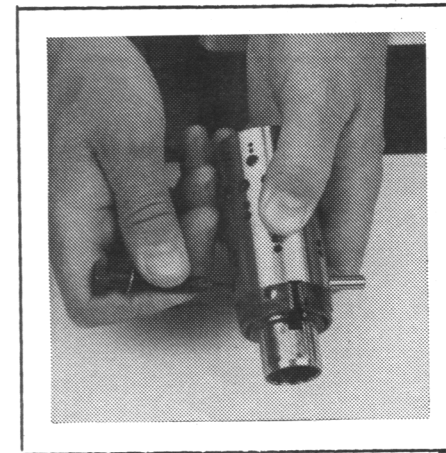

11 Press out the cross pin. Use the special screw from the end cover.

Note 11a!

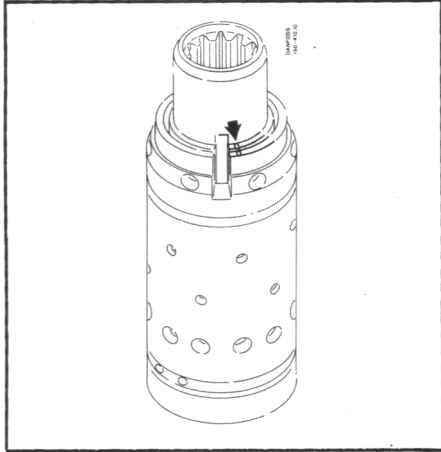

11a OSP/B CN and OSP/C CN

A small mark has been made with a pumice stone on both spool and sleeve close to one of the slots for the neutral position springs (see drawing).

If the mark is not visible, remember to leave a mark of your own on sleeve and spool before the neutral position springs are dismantled.

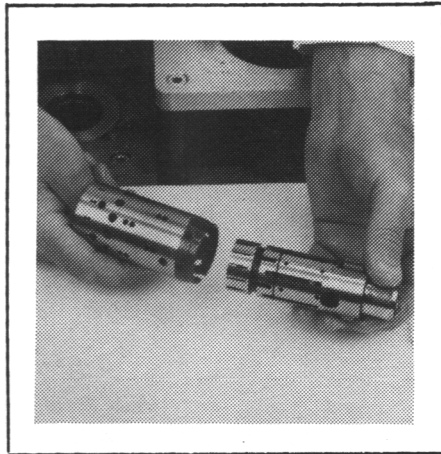

12 Carefully press the spool out of the sleeve.

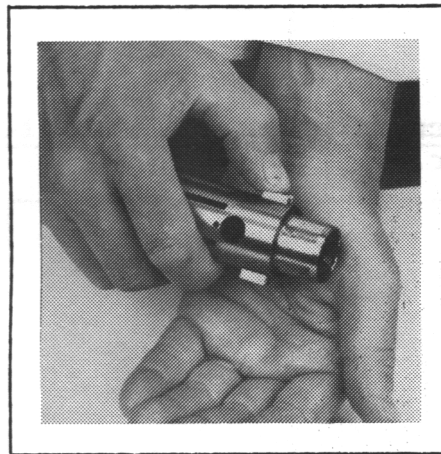

13 Press the neutral position springs out of their slots in the spool.

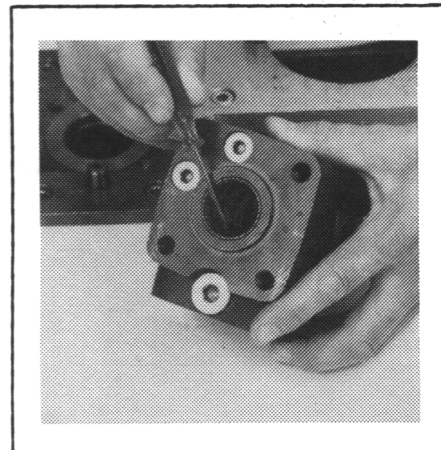

14 Remove dust seal and o-ring/kin-ring.



Dismantling the dual shock valves for OSPC/OSPC LS

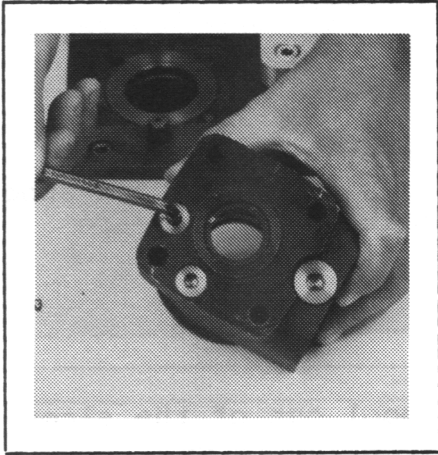

15 Remove plugs from shock valves using a 6 mm hexagon socket spanner.

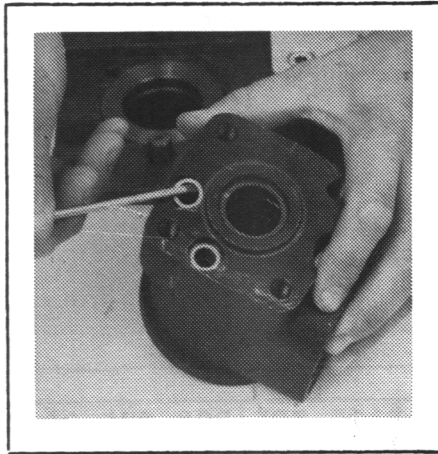

16 Remove seal washers (2-off).

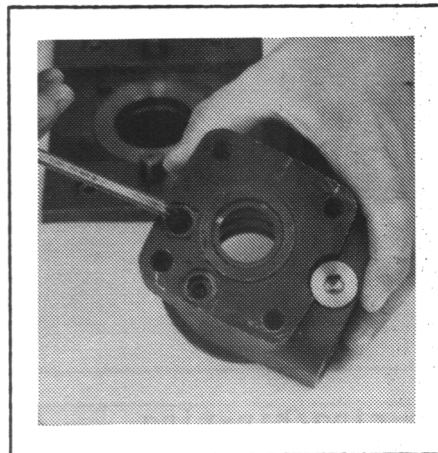

17 Unscrew the setting screws using a 6 mm hexagon socket spanner.



18 Shake out the two springs and two valve balls into your hand. The valve seats are bonded into the housing and cannot be removed.

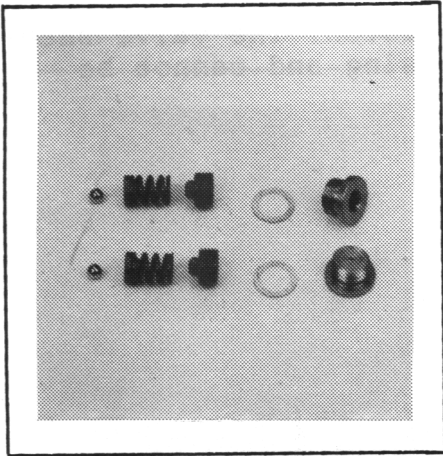

19 The dual shock valves are now dismantled.

Dismantling the pressure relief valve (cartridge) for OSPC

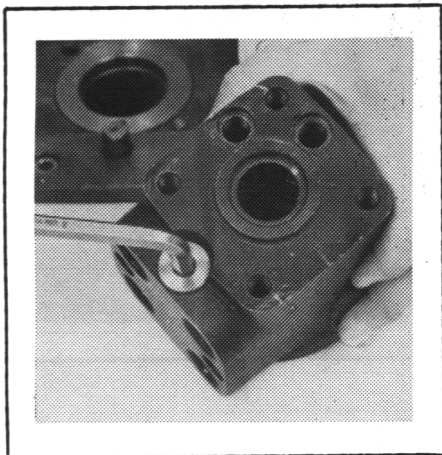

20 Screw out the plug using an 8 mm hexagon socket spanner. Remove seal washers.

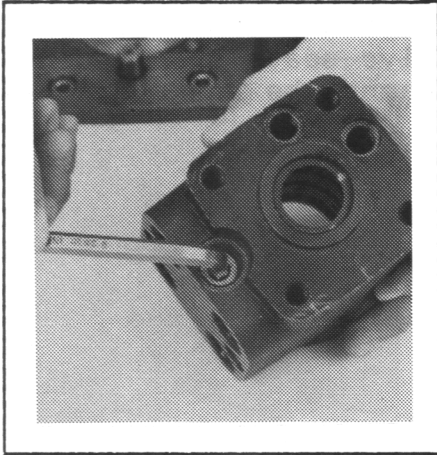

21 Unscrew the setting screw using an 8 mm hexagon socket spanner.

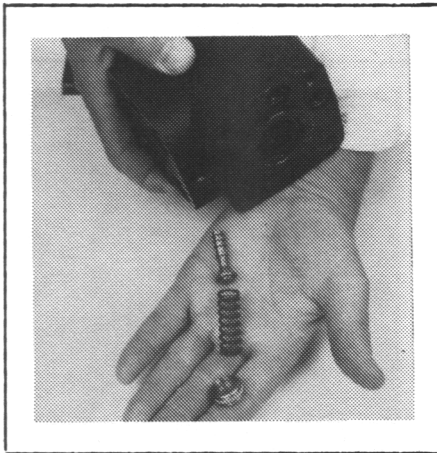

22 Shake out spring and piston. The valve seat is bonded into the housing and cannot be removed.

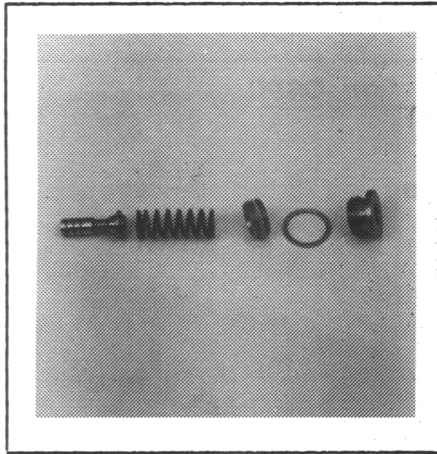

23 The pressure relief valve is now dismantled.



Dismantling the pressure relief valve (cartridge) for OSPC LS/OSPC LSR

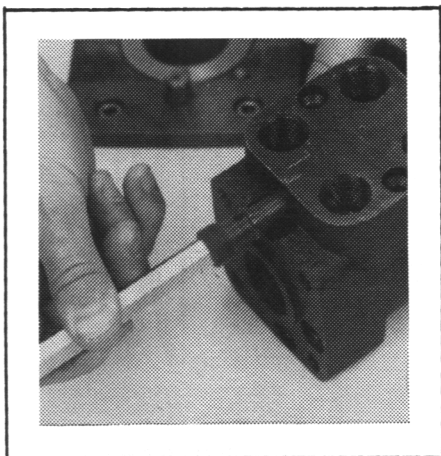

24 Screw out the pressure relief valve using an 8 mm hexagon socket spanner. Remove the seal ring. If the valve is defective it must be replaced (see OSPC spare parts list, HN.21.CA.52).

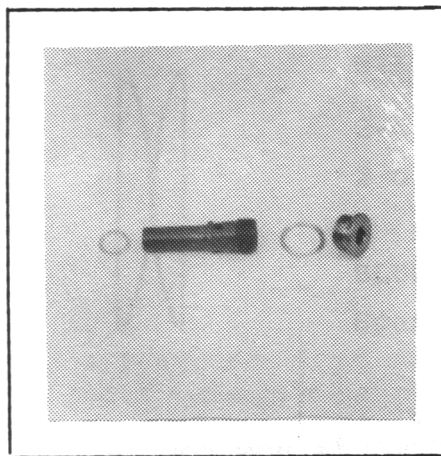

25 The pressure relief valve is now dismantled.

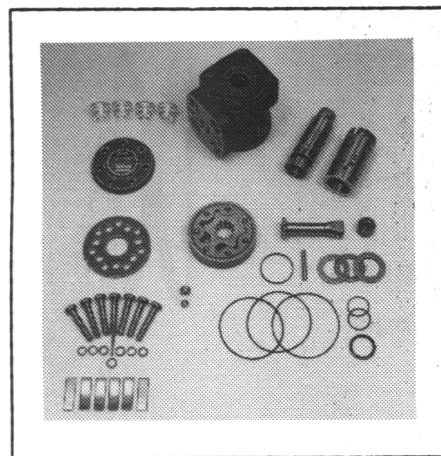

26 The steering unit OSPB is now completely dismantled.

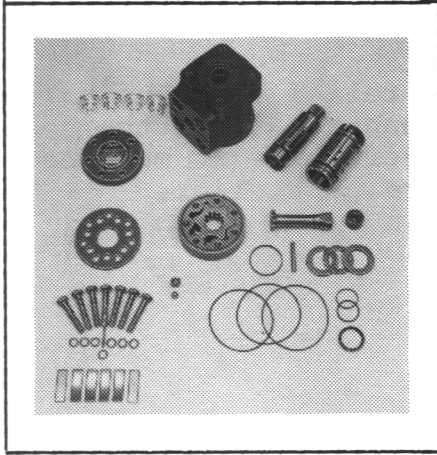

27 The steering unit OSPB LS is now completely dismantled.

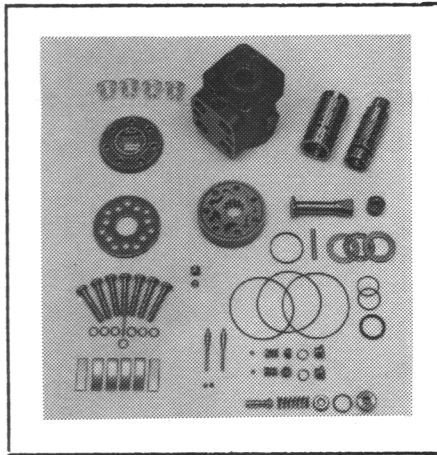

28 The steering unit OSPC is now completely dismantled.

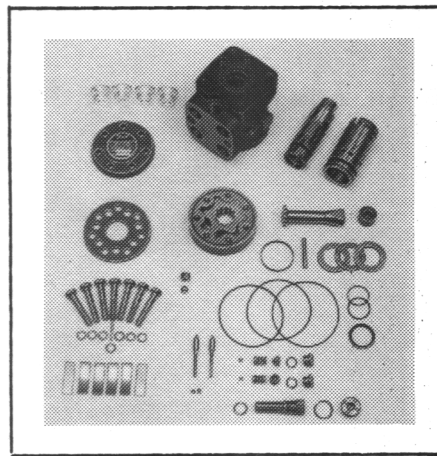

29 The steering unit OSPC LS is now completely dismantled.

Cleaning

Clean all parts carefully in Shellsol K or the like.

Inspection and replacement

Replace all seals and washers. Check all parts carefully and make any replacements necessary.

Lubrication

Before assembly, lubricate all parts with hydraulic oil.



Assembly pattern and colour code for neutral position springs for OSP-steering units

STANDARD SPRINGS (GREY)



DANFOSS
150-386.0

2-off flat, grey: code no. 150-0720
4-off curved, grey: code no. 150-0721

GREY SET

Spare set: code no. 150-4209

WEAK SPRINGS (BLUE)



2-off flat, blue: code no. 150-0748
2-off curved, blue: code no. 150-0749

BLUE SET

Spare set: code no. 150-4265

STRONG SPRINGS (GREY AND BLUE)



2-off flat, grey: code no. 150-0720
4-off curved, blue: code no. 150-0749

GREY/BLUE SET

Spare set: code no. 150-4207

STIFF SPRINGS (YELLOW)



2-off flat, yellow: code no. 150N0602
2-off curved, yellow: code no. 150N0603

YELLOW SET

Spare set: code no. 150-4269



REASSEMBLY

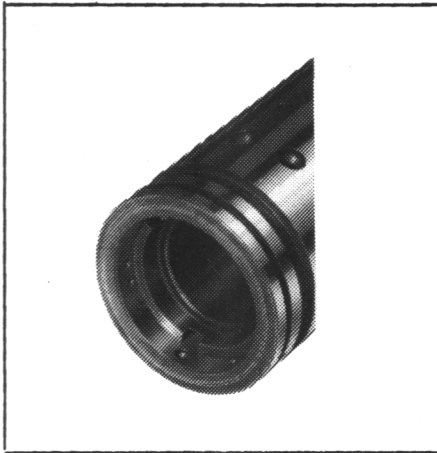

30 Assemble spool and sleeve.

Note

OSPB LS, OSPBX LS, OSPC LS and OSPC LSR
When assembling spool and sleeve only one of two possible ways of positioning the spring slots is correct. There are three slots in the spool and three holes in the sleeve in the end of the spool/sleeve opposite to the end with spring slots. Place the slots and holes opposite each other so that parts of the holes in the sleeve are visible through the slots in the spool.

OSPB CN and OSPC CN

Assemble the spool/sleeve and make sure the marks on spool and sleeve are opposite each other (see drawing page 7).

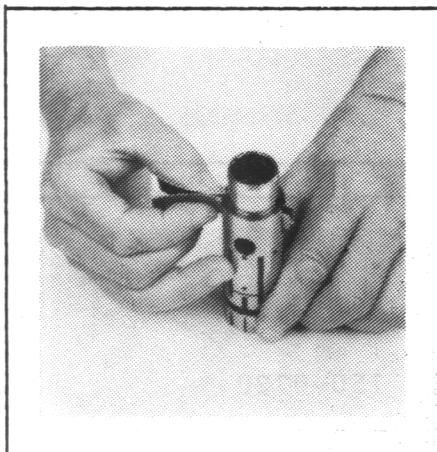

31 Place the two flat neutral position springs in the slot.

Place the curved springs between the flat ones and press them into place (see assembly pattern, page 13).

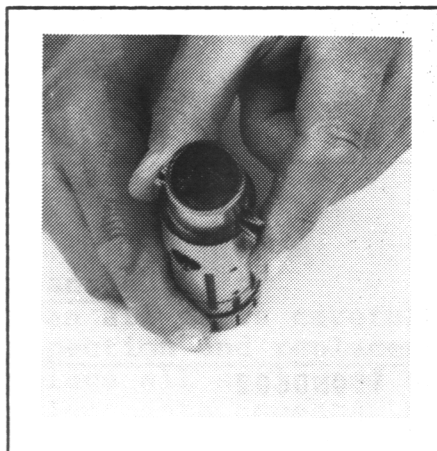

32 Line up the spring set.

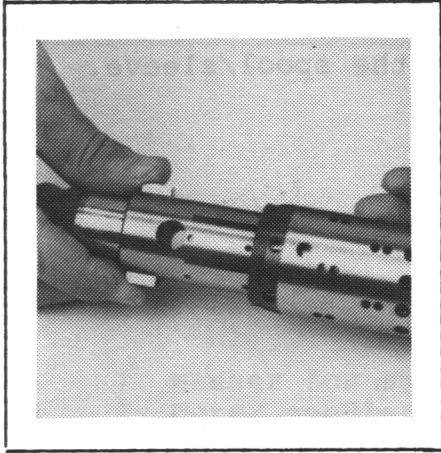

33 Guide the spool into the sleeve. Make sure that spool and sleeve for OSPB LS, OSPBX LS, OSPC LS and OSPC LSR are placed correctly in relation to each other (see page 14).

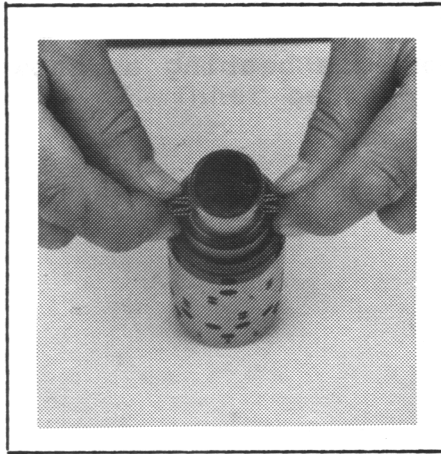

34 Press the springs together and push the neutral position springs into place in the sleeve.

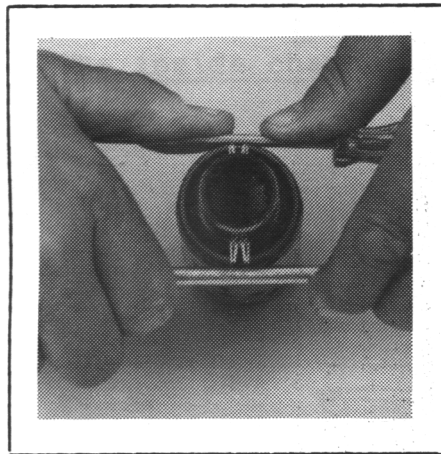

35 Line up the springs and centre them.

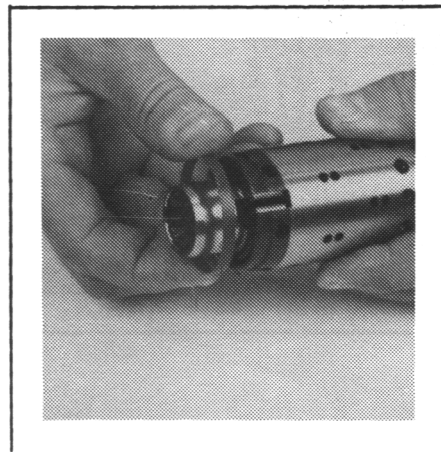

36 Guide the ring down over the sleeve.

Note: The ring should be able to rotate - free of the springs.

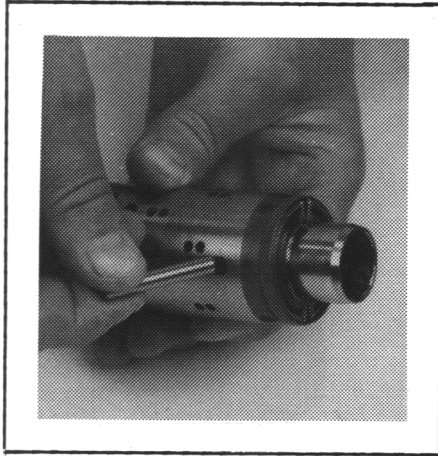

37 Fit the cross pin into the spool/sleeve.

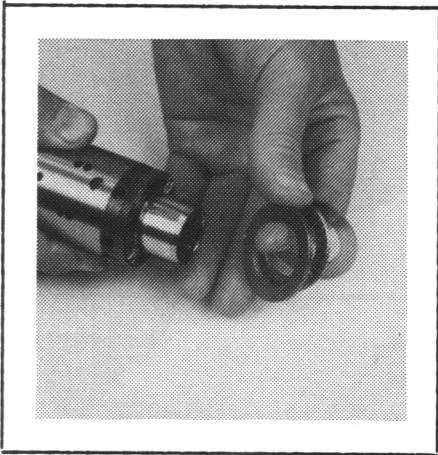

38 Fit bearing races and needle bearing as shown on below drawing.

Assembly pattern for standard bearings

- 1 Outer bearing race
- 2 Needlebearing
- 3 Inner bearing race
- 4 Spool
- 5 Sleeve

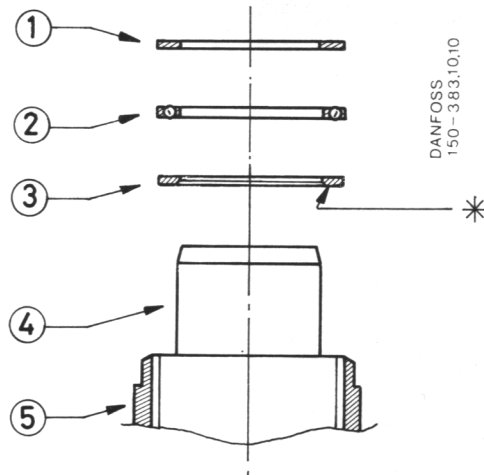



Assembly pattern for double bearings

- 1 Washer for axial bearing
- 2 Outer needlebearing
- 3 Outer bearing race
- 4 Spool
- 5 Sleeve
- 6 Inner needlebearing
- 7 Inner bearing race

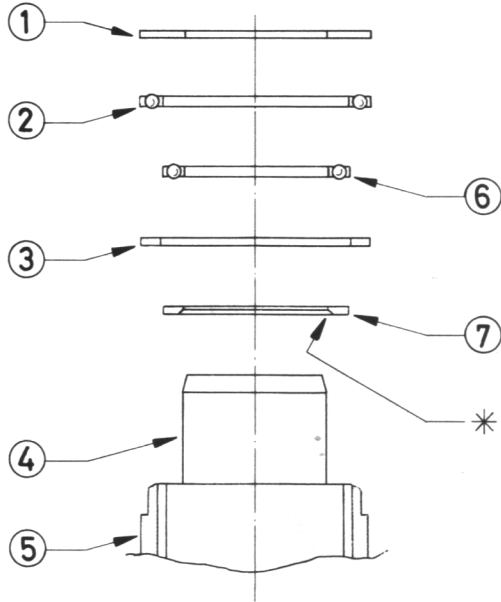

DANFOSS
150-33610,21

The inside chamfer on the inner bearing race must face the inner spool.

Installation instructions for o-ring/kin-ring (standard)

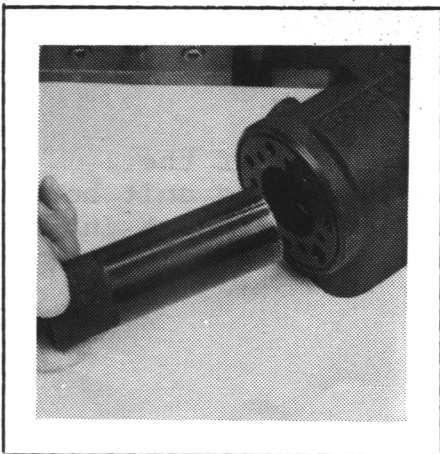

39 Turn the steering unit until the bore is horizontal. Guide the outer part of the assembly tool into the bore for the spool/sleeve.

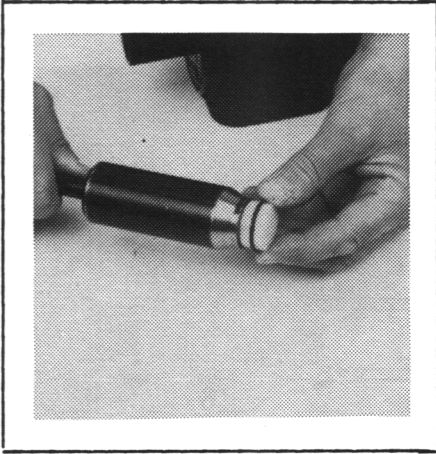

40 Grease o-ring and kin-ring with hydraulic oil and place them on the tool.

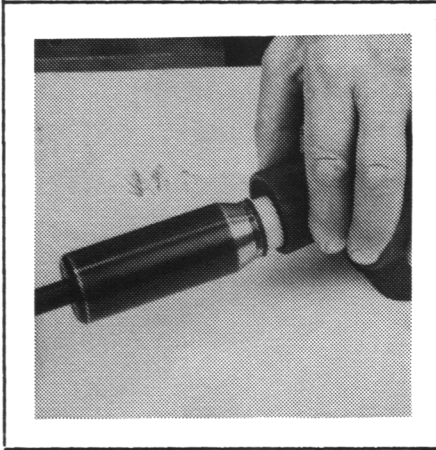
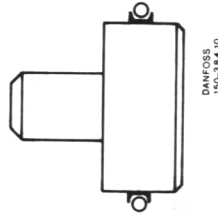

41 Hold the outer part of the assembly tool in the bottom of the steering unit housing and guide the inner part of the tool right to the bottom.

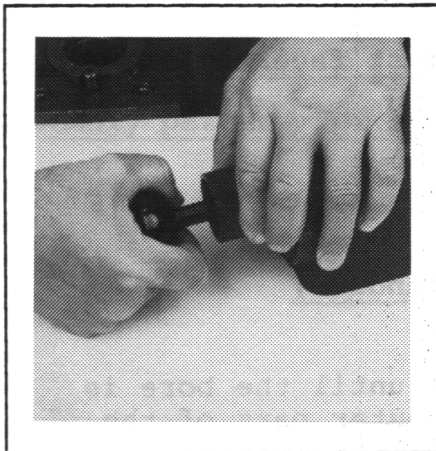

42 Press and turn the o-ring/kin-ring into position in the housing.

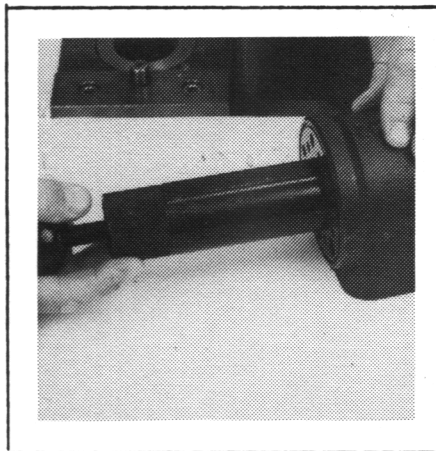

43 Draw the inner and outer parts of the assembly tool out of the steering unit bore, leaving the guide from the inner part in the bore.



Installation instructions for lip seal

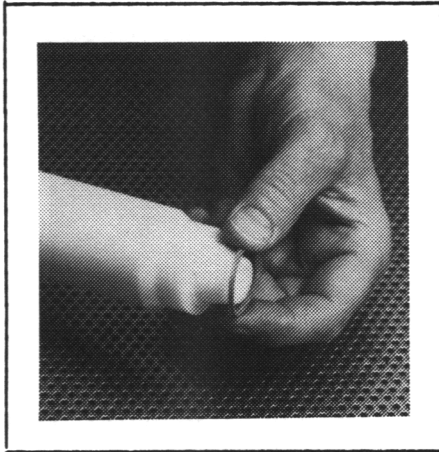

44 Lubricate the lip seal with hydraulic oil and place it on the assembly tool.

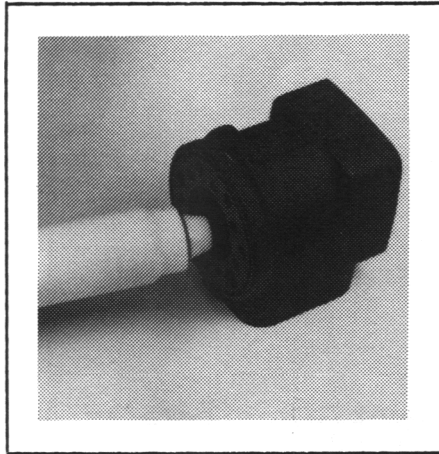
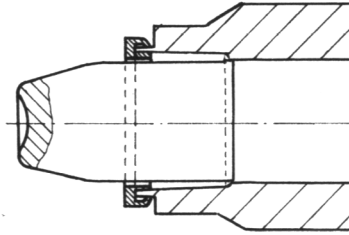

45 Guide the assembly tool right to the bottom.



46 Press and turn the lip seal into place in the housing.

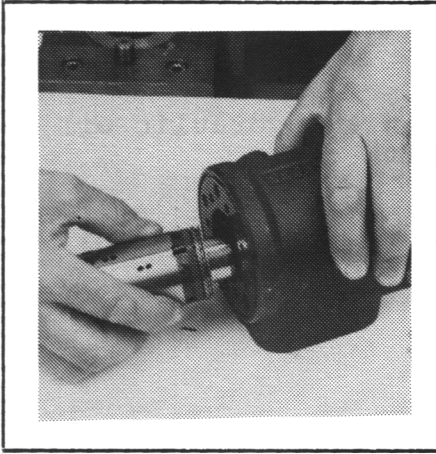

47 With a light turning movement, guide the spool and sleeve into the bore.

Note: Fit the spool set holding the cross pin horizontal.



48 The spool set will push out the assembly tool guide. The o-ring and kin-ring are now in position.

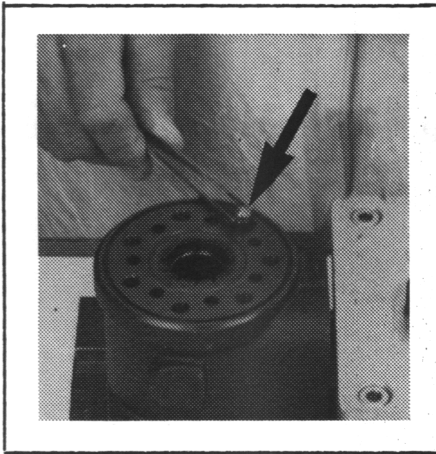

49 Turn the steering unit until the bore is vertical again. Put the check valve ball into the hole indicated by the arrow.

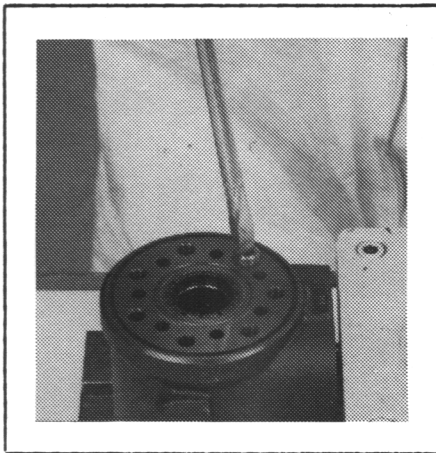

50 Screw the threaded bush lightly into the check valve bore. The top of the bush must lie just below the surface of the housing.



Assembly of the two suction valves for OSPC/OSPC LS/OSPC LSR

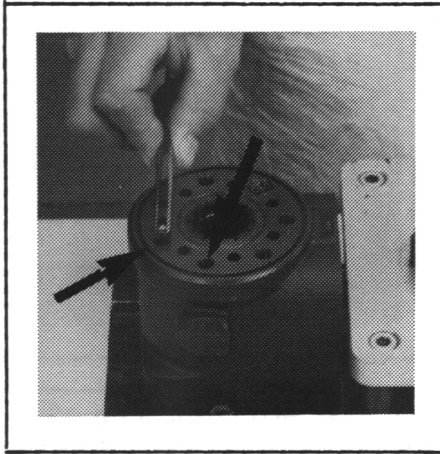

51 Place a ball in the two holes indicated by the arrows.

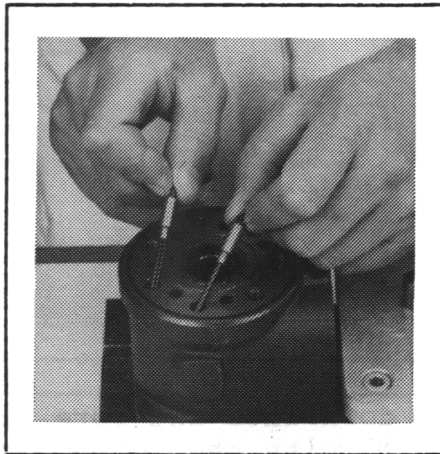

52 Place a pin in the same two holes.

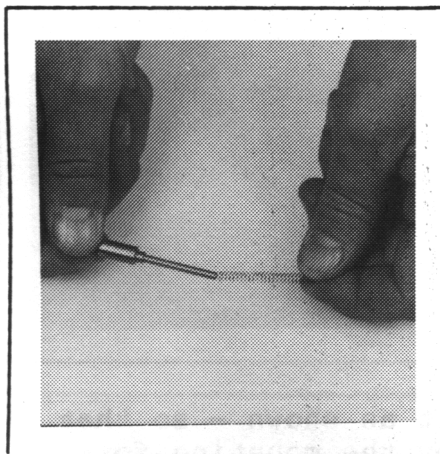

53 In some cases a spring has to be fitted (see page 30, pos. 28) on the pin before it is placed in the housing. (See OSPC spare parts list, HN.21.CA.52).

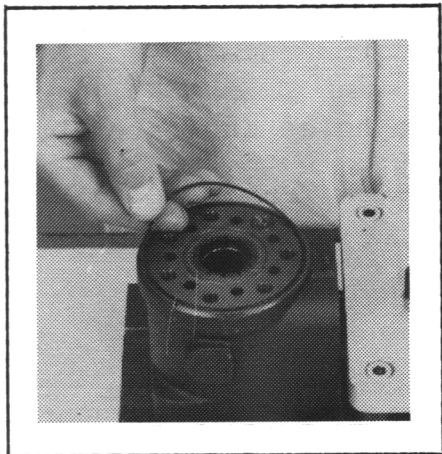

54 Grease the o-ring with mineral oil approx. viscosity 500 cSt at 20°C.

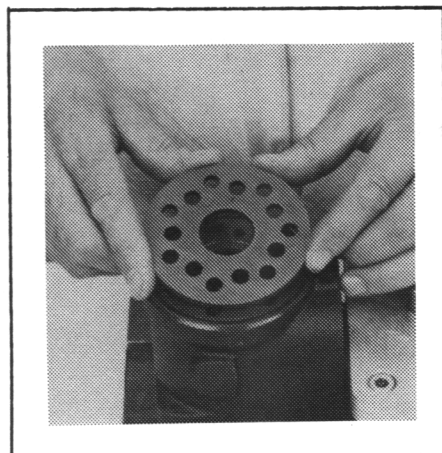

55 Place the distributor plate so that the channel holes match the holes in the housing.

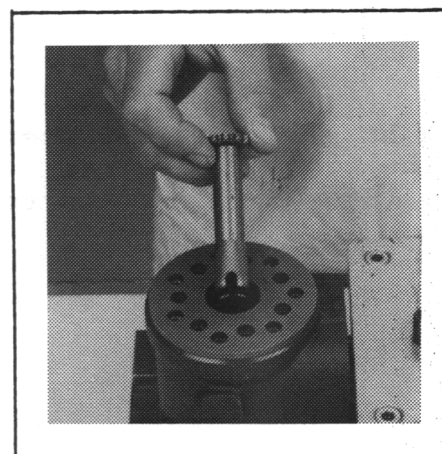

56 Guide the cardan shaft down into the bore so that the slot is parallel with the connection flange.

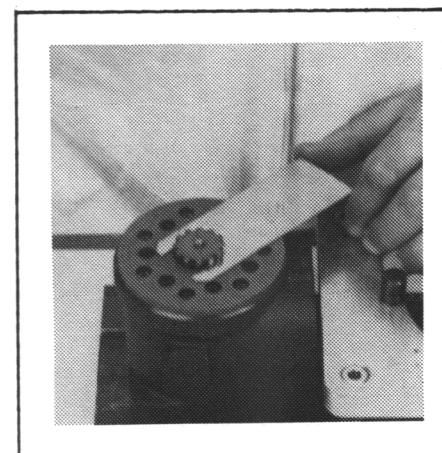

57 Place the cardan shaft as shown - so that it is held in position by the mounting fork.

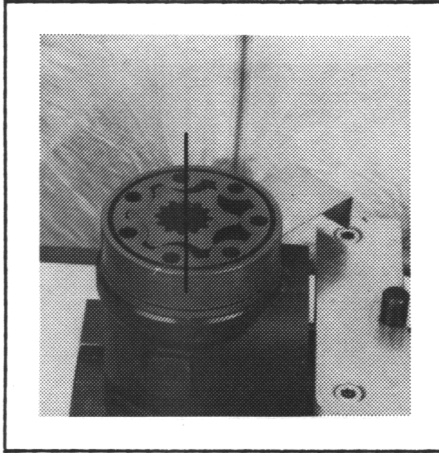

58 Grease the two o-rings with mineral oil approx. viscosity 500 cSt at 20°C and place them in the two grooves in the gear rim. Fit the gearwheel and rim on the cardan shaft.

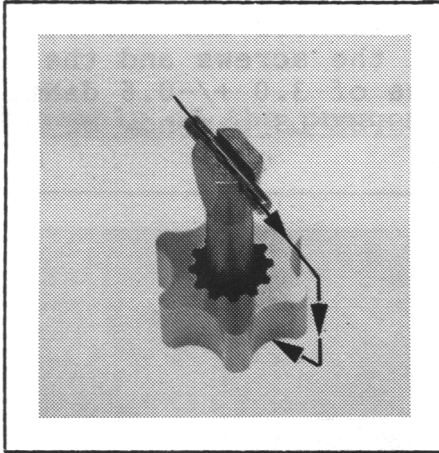

59 Important: Fit the gearwheel (rotor) and cardan shaft so that a tooth base in the rotor is positioned in relation to the shaft slot as shown. Turn the gear rim so that the seven through holes match the holes in the housing

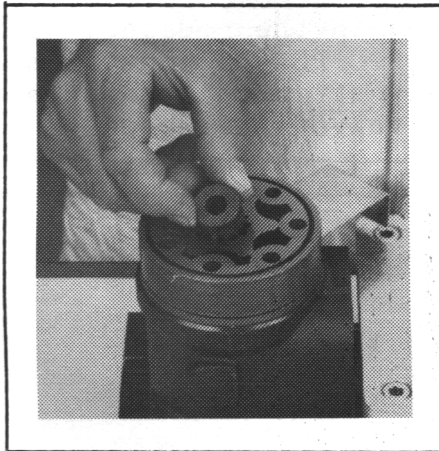

60 Fit the spacer, if any.

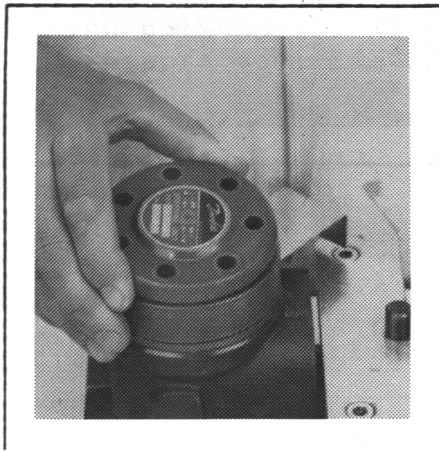

61 Place the end cover in position.

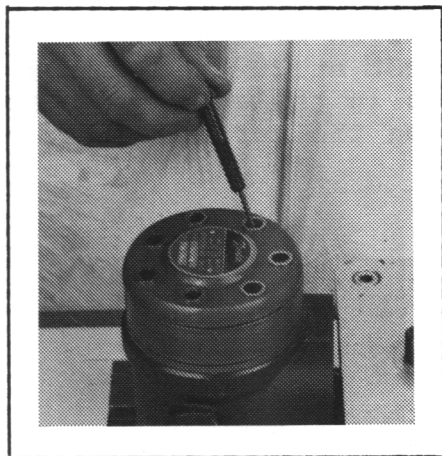

62 Fit the special screw with washer and place it in the hole shown.

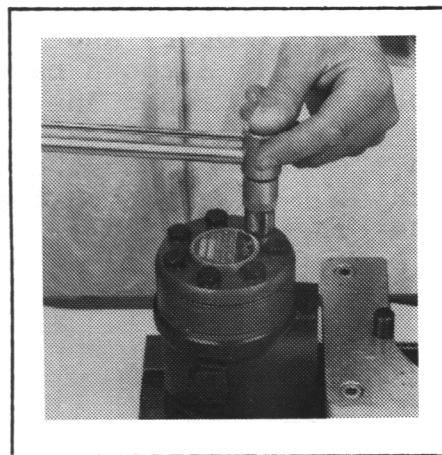

63 Fit the six screws with washers and insert them. Cross-tighten all the screws and the rolled pin with a torque of 3.0 ± 0.6 daNm. The OSPB, OSPB LS and OSPBX LS can now be function tested.

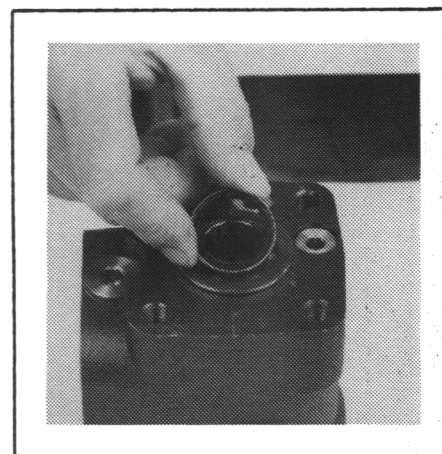

64 Place the dust seal ring in the housing. With the OSPC, PSPC LS and OSPC LSR the dust seal ring must be placed only after the pressure relief valve and shock valves have been fitted.

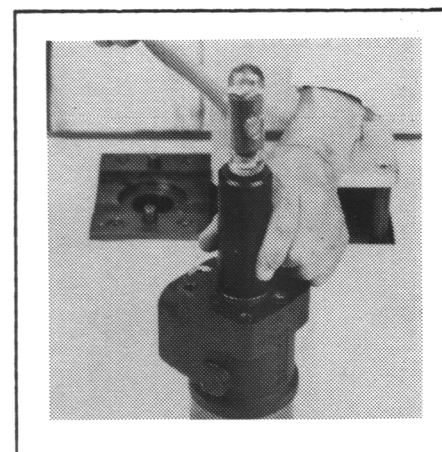

65 Fit the dust seal ring in the housing using special tool SJ 150-9000-22 (see page 3; E) and a plastic hammer.



66 Press the plastic plugs into the connection ports. Do not use a hammer!

Assembly of the pressure relief valve for OSPC

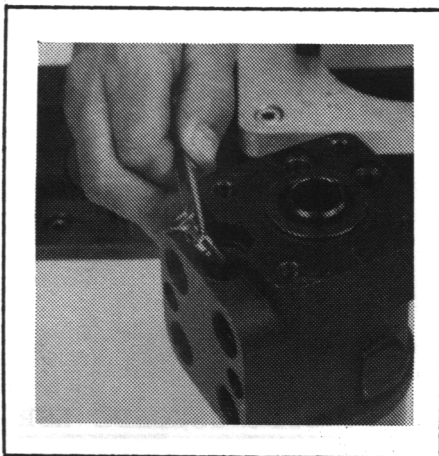

67 Fit the piston.

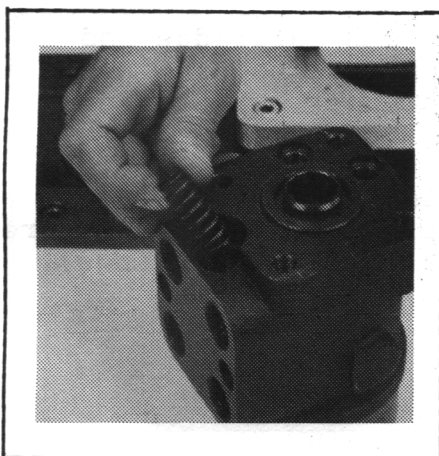

68 Fit the spring.

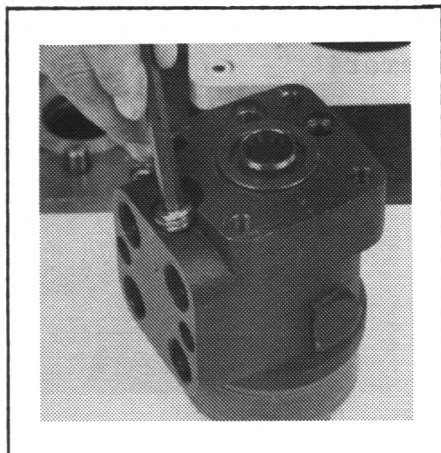

69 Screw in the setting screw with an 8 mm hexagon socket spanner. Make the pressure setting on a panel or the vehicle.

Ø 1.7 spring for 50 - 70 bar.

Ø 1.9 spring for 70 - 105 bar.

Ø 2.1 spring for 110 - 155 bar.

(See OSPC spare parts list HN.21.CA.52).

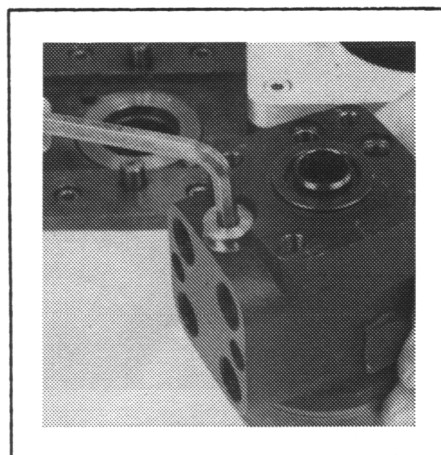

70 Screw plug with dust seal into the housing using an 8 mm hexagon socket spanner.

Tightening torque: 5 +/-1 daNm.

Assembly of the pressure relief valve (cartridge) for OSPC LS/OSPC LSR

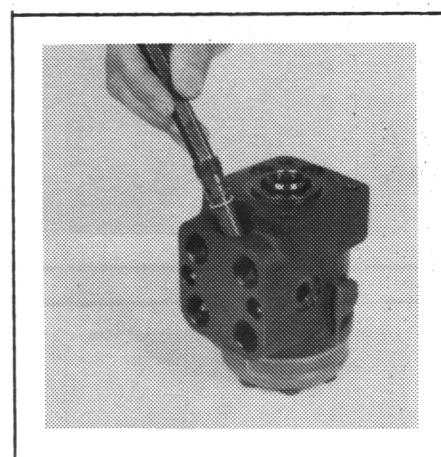

71 Place the seal ring on the cartridge and screw the cartridge into the housing using a 12 mm hexagon socket spanner. Tightening torque: 5 +/-1 daNm. Make the pressure setting on a panel or the vehicle. The cartridge is factory-set at 175 bar. Use a 4 mm hexagon socket spanner. (See OSPC spare parts list HN.21.CA.52 for setting range).

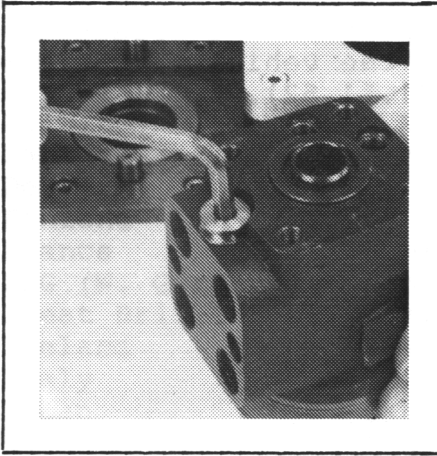

72 Screw plug with seal ring into the housing using an 8 mm Allen key.

Tightening torque: 5 +/-1 daNm.

Assembly of the dual shock valves for OSPC/OSPC LS/OSPC LSR

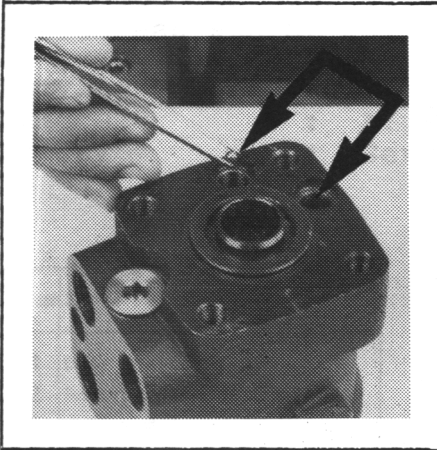

73 Put a ball in the two holes indicated by the arrows.

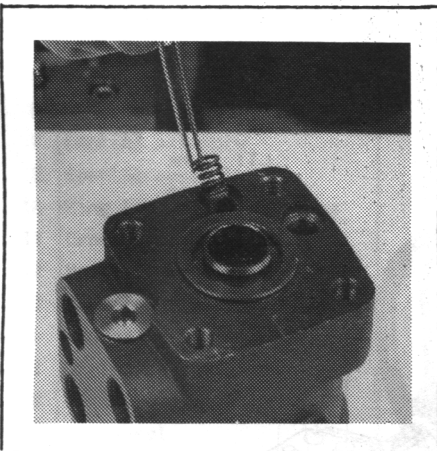

74 Place springs and valve cones over the two balls.

Note:

The blue spring applies to setting range 90-180 bar. The untreated spring applies to setting range 190-260 bar. (See OSPC spare parts list HN.21.CA.52).

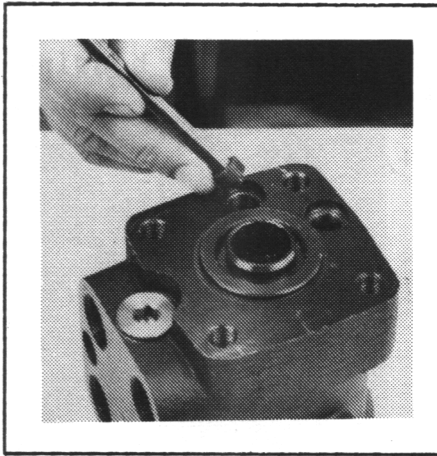

75 Screw in the two setting screws using a 6 mm hexagon socket spanner. Make the pressure setting on a panel or the vehicle. (See OSPC spare parts list HN.21.L1.52).

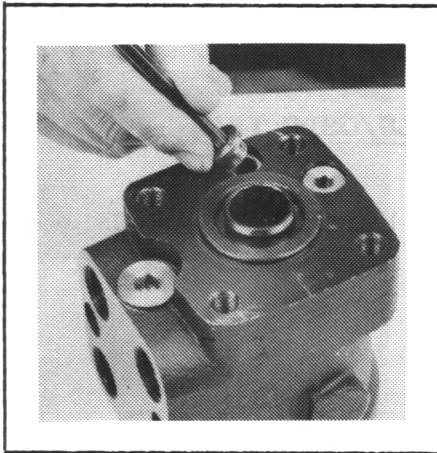

76 Screw plug with seal ring into the two shock valves and tighten them with a torque of 3 +/-0 daNm using a 6 mm hexagon socket spanner.

Steering unit type OSPB, OSPB LS, OSPBX LS, OSPC, OSPC LS or OSPC LSR is now assembled.

Max. tightening torque and hydraulic connections

Screwed connection	Max. tightening torque daNm (lbf in)			
	With cutting edge	With copper washer	With aluminium washer	With O-ring
1/4 BSP.F	4 (350)	2 (180)	3 (270)	
3/8 BSP.F	6 (530)	2 (180)	5 (440)	
1/2 BSP.F	10 (900)	3 (270)	8 (700)	
7/16-20 UNF				2 (180)
3/4-16 UNF				6 (530)
M 12 x 1,5	4 (350)	2 (180)	3 (270)	2 (180)
M 18 x 1,5	7 (620)	2 (180)	5 (440)	5 (440)
M 22 x 1,5	10 (900)	3 (270)	8 (700)	7 (620)

L: Left port
R: Right port
T: Tank
P: Pump

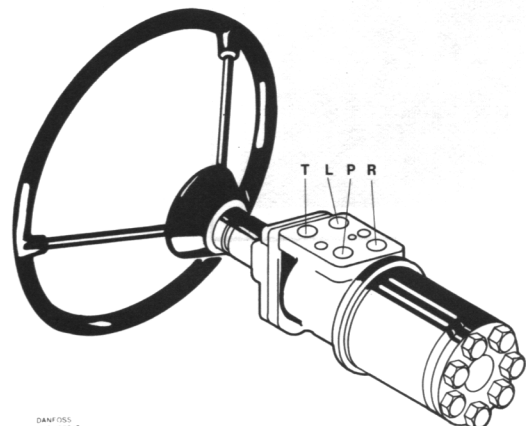

DANFOSS
150 342/2



Authorized service shops:

- Asean : Danfoss Industries Pte. Ltd., Singapore
- Australia : Danfoss (Australia) Pty. Ltd., Melbourne
- Austria : Hainzl Industriesysteme, Gesellschaft m.b.H, Linz
- Belgium : N.V. Danfoss S.A., Bruxelles
- Canada : Danfoss Mfg. Co. Ltd., Mississauga
- Denmark : H. Søndergaard A/S, Måløv
- Finland : OY Danfoss AB, Espoo
- France : Danfoss S.a.r.l., Trappes (Paris)
- FRG (W. Germany) : Danfoss GmbH, Offenbach/Main
- Great Britain : Danfoss Limited, Greenford
- Iceland : Velsmidjan Hedinn, Reykjavik
- Italy : Sordella & C. Oleodinamica s.r.l., Torino
- Japan : Danfoss (Japan) Manufacturing Co., Ltd., Gotemba
- Netherlands : ITHO B.V., Schiedam
- New Zealand : Danfoss (New Zealand) Limited, Auckland
- Norway : Danfoss Norge A/S, Skui
- Spain : Danfoss S.A., Madrid
- Sweden : Transventor Hydraulik AB, Mölndal, Göteborg
- Switzerland : Werner Kuster AG, Frenkendorf
- U.S.A. : Danfoss Inc., Rockford, Illinois

Service shops:

- Greece : A. Skoura & Co. E.E., Athens
- Norway : Servi Produksjon A.S., Trondheim

Item	Spare Parts
1	Dust seal ring
2	Housing + spool + sleeve
3	Ball \varnothing 8,5 mm
4	Thread bushing
5	O-ring 25, 12x1,78 mm, is used with kin-ring (item 6)
6	Kin-ring
6a	Lip seal
7	Bearing assembly
8	Bearing assembly
10	Ring I/D 39,6x0,7x4,5 mm
11	Cross pin \varnothing 6x41 mm
12	Neutral position spring
13	Cardan shaft
14	Spacer
15	O-ring \varnothing 80,5x1,5 mm
16	Distributor plate
17	Gearwheel
18	O-ring \varnothing 75,92x1,78 mm
19	End cover
20	Washer \varnothing 8,2x11,9x1,0 mm
22	Special screw
23	Screw
24	Rating plate
25	Drive screw
26	Spacer

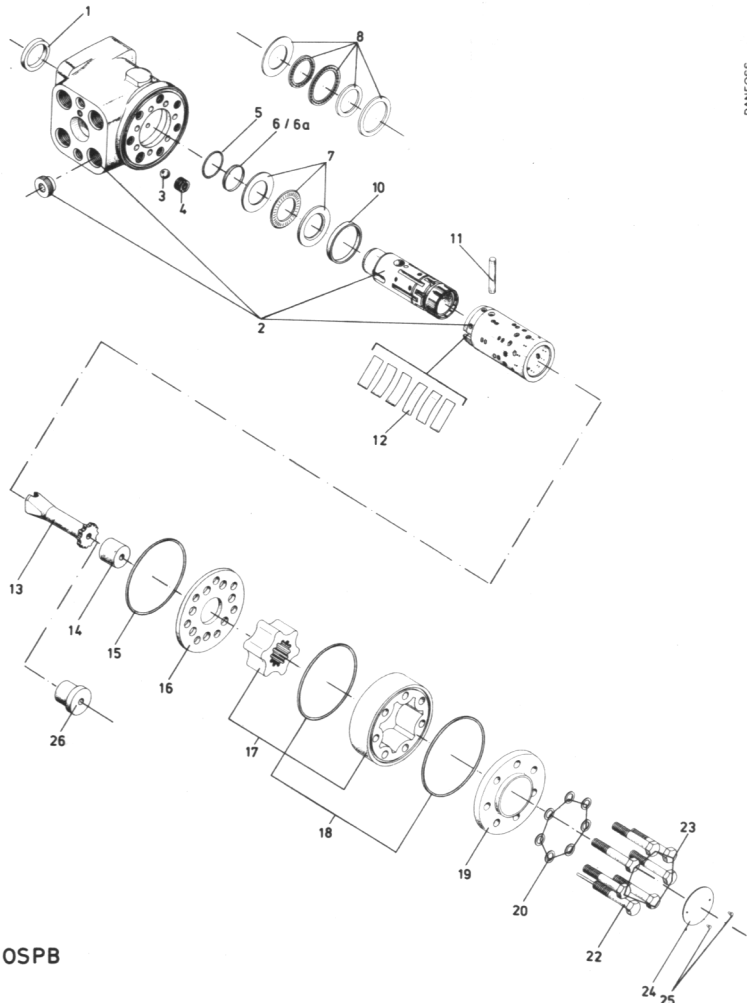

OSPB

DANFOSS 150-385.11.12



Item	Spare Parts
1	Dust seal ring
2	Housing, spool and sleeve
3	Check valve and the seats for relief and dual shock valves are locktited
4	Ball $\varnothing 8,5$ mm
5	Thread bushing
6	O-ring used with kin-ring (item 6)
7	Kin-ring
8	Bearing assembly
9	Ring
10	Cross pin
11	Spacer
12	Cardan shaft
13	Set of springs
14	O-ring
15	Distributor plate
16	Gearwheel set
17	O-ring
18	End cover
19	Washer
20	Special screw
21	Screw
22	Name plate
23	Drive screw
24	Complete relief valve
25	Spring wire $\varnothing 1,7 \times 36,6$ long
26	Complete dual shock valve
27	Ball $\varnothing 3/16$ in
28	Spring
29	Rolled pin

